



DBK4™

2-Channel Dynamic Signal-Input Card



Compatibility: ✓ LogBook ✓ DaqBook ✓ DaqLab ✓ DaqScan ✓ DaqBoard/2000 Series

Features

- Provides two dynamic analog inputs
- Offers a per-channel programmable gain amplifier for ± 50 mV, ± 500 mV, or ± 5 V FS input
- Includes a built-in current source for ICP® transducer biasing
- Offers per-channel anti-aliasing filters with eight software programmable cutoff frequencies from 141.6 Hz to 18 kHz
- Provides per-channel simultaneous sample & hold
- Accommodates either AC or DC coupled signals
- Includes BNC connectors and footprints for two user-provided Microdot™ connectors
- Both dynamic analog inputs sampled within 50 ns of each other



The 2-channel DBK4 provides systems with the ability to accept dynamic signal sources

The 2-channel DBK4™ dynamic signal-input card enables IOtech's data acquisition systems to accommodate inputs from piezoelectric transducers, such as accelerometers or microphones, as well as from various other dynamic signal sources. Each DBK4 card is equipped with two BNC connectors and footprints for two user-installed Microdot™ connectors, permitting it to easily accommodate most transducer connections. Up to 128 cards can be attached to one system for a total of 256 dynamic signal inputs.

Architecture. The DBK4 provides per-channel, constant current source outputs, programmable gain amplifiers, programmable anti-aliasing filters, and simultaneous sample and hold amplifiers.

Current Source. The DBK4's constant current source can be jumper-set to either 2 or 4 mA. The card can also be configured to disable the current source via jumpers, enabling its use in applications that require only programmable gain, programmable filtering, and simultaneous sample and hold.

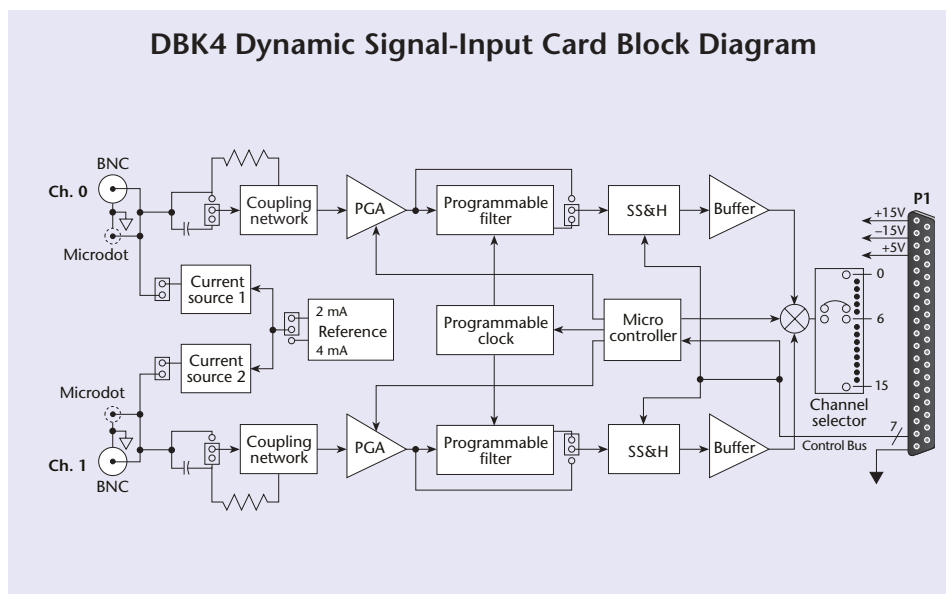

Programmable Gain. The DBK4's programmable gain amplifier accepts full-scale inputs of ± 50 mV, ± 500 mV, or ± 5 V. Because its gain is software-selectable per channel, the card can accommodate a different gain on each channel.

Anti-Aliasing Filter. The card's programmable low-pass Butterworth filter can be software set to one of eight different cutoff frequencies, from 141.6 Hz to 18 kHz, on a per-channel basis. The anti-aliasing filter can also be bypassed, expanding the card's bandwidth up to 40 kHz per channel.



DBK4™

Specifications & Ordering Information

Sample and Hold Amplifier*. The card's sample and hold amplifier allows all channels in a system (up to 256) to be sampled within 50 ns of one another.

Power Note: Depending upon system configuration, a system may require supplemental power to run DBK expansion options. For complete analysis, see system power requirements worksheet on p. 115 to calculate your specific needs.

Specifications

Channels: 2
Connectors: DB37 male, mates with P1**; 1 BNC per channel and footprints for one user-provided Microdot™ connector per channel
Current Source
Output Impedance: >1.4M Ohm
Compliance: 27V
Current Levels: 2 and 4 mA (jumper selectable)
Broadband Noise: 0.3 µA RMS (BW=100 kHz)
Input Impedance: 150K Ohm
Input Ranges: ±50 mV, ±500 mV, and ±5V FS; additional full scale ranges are available when combined with the LogBook's, DaqBook's, or DaqBoard's on-board programmable A/D ranges
Coupling: AC and DC
AC High-Pass Filters: Per-channel, 1-pole HPF with 10-Hz or 0.1-Hz cutoff, selectable via jumper
Input Signal/Noise: >96 dB (BW=100 kHz)
Amplitude Accuracy: ±0.5 dB passband center
Low-Pass Filter: Software selectable, 12-pole Butterworth filter, with cutoff frequencies of 18 kHz, 9 kHz, 4.5 kHz, 2.25 kHz, 1.125 kHz, 562.5 Hz, 281.2 Hz, and 141.6 Hz; each channel can be configured for a different cutoff frequency
Distortion
Bypass Mode: @ 1 kHz -85 dB, @ 10 kHz -82 dB
Filter Mode: @ 1 kHz -75 dB, @ 10 kHz -72 dB
Flatness DC-80% Fc: ±0.2 dB
Phase Matching DC-80% Fc: See accompanying chart
Accuracy Passband Center: ±0.5 dB
Power Consumption: 2750 mW

Phase Matching Frequency Cutoff	
Corner Frequency	Typical Phase Match
18 kHz	±3.0°
9 kHz	±1.3°
4.5 kHz	±0.7°
2.25 kHz	±0.6°
1.125 Hz	±0.5°
563 Hz	±0.5°
281 Hz	±0.5°
141 Hz	±0.5°

Ordering Information

Description	Part No.
2-channel dynamic signal-input card	DBK4

Cables

For use with DBK10, use CA-37-x ribbon cable, or contact factory of additional cabling options
 For use with DBK60 or LogBook360, no cable is required (except from DBK60 or LogBook/360 to the A/D mainframe)
 For use with no enclosure, use CA-37-x where x is the number of DBK devices attached
 For use with DaqLab series (internal slots), use CA-255-2T with one board, or CA-37-2 for use with two DBK cards (or contact factory for additional cabling options)

For complete information on accessories and cables, visit www.iotech.com/acc

Related Products	
LogBook	p. 75
DaqBook	p. 89
DaqLab	p. 103
DaqScan	p. 108
DBK10	p. 126
DBK32A	p. 143
DBK41	p. 146
DBK60	p. 160
DaqBoard/2000 Series	p. 192

* In systems incorporating DBK products with SS&H, the per-channel rate is [Maximum A/D rate/(n + 1)], where n=number of channels.
 ** Attachment to the DaqBoard/2000 series requires a DBK200, DBK201, DBK202, DBK203, DBK205, or DBK209 adapter
 † Not for use in piezoelectric applications